

REV	DESCRIPTION	DATE	BY
A	NEW DRAWING	03/04/04	H.N.

SKT1771  
DOD 41771

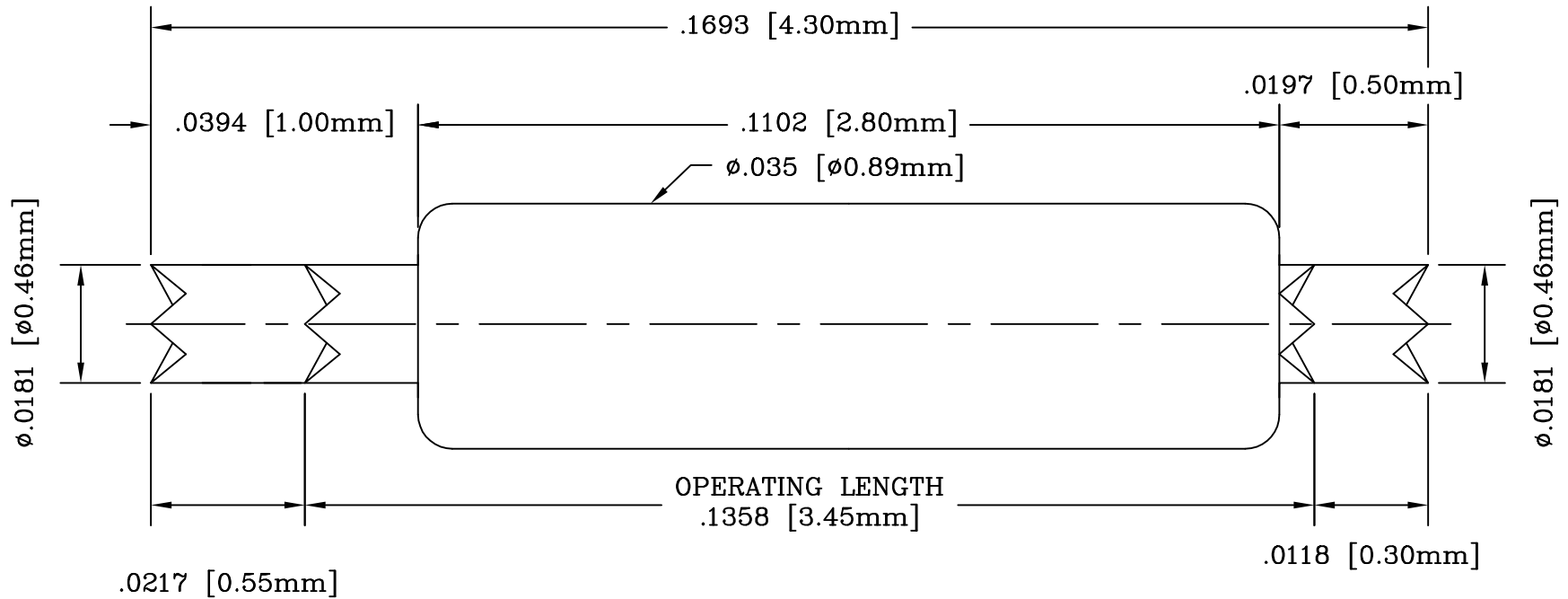

**SPRING FORCE:**

5.00g(0.176oz) AT INITIAL TRAVEL  
 28.00g(0.988oz) AT .0335 [0.85mm] RECOMMENDED TRAVEL  
 30.00g(1.058oz) AT .0374 [0.95mm] FULL TRAVEL

**MATERIAL & FINISH:**

PLUNGER HARDENED BERYLLIUM COPPER / GOLD PLATED  
 BARREL BRASS / GOLD PLATED  
 SPRING STAINLESS WIRE / GOLD PLATED

ALL DIMENSIONS ARE IN INCHES UNLESS OTHERWISE SPECIFIED

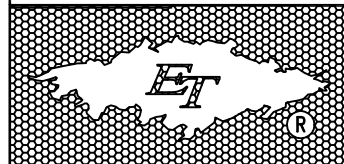

**Emulation Technology, Inc.**

— VLSI and SMT ADAPTERS and ACCESSORIES —

2344 Walsh Avenue, Bldg.F TEL:(408)982-0660  
 Santa Clara, Ca 95051 FAX:(408)982-0664

SHEET: 1 OF 1	DATE: 03/04/04	REVISION: A	<b>ASSEMBLY DRAWING</b>
CHECKED: Perry Munroe	DRAWN: Huy Nguyen	ITEM: POGO-PIN-4.30-1	DESCRIPTION: POGO-PIN-4.30-1
Scale N/A	DO NOT SCALE DRAWING		