

DIMENSIONS ARE IN[MILLIMETERS]

SKT001
DOD 4001

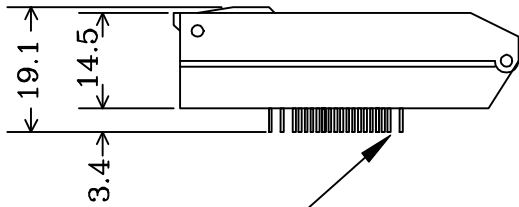

CONTACT IS
.009" [.23mm]
X.018" [.45mm]

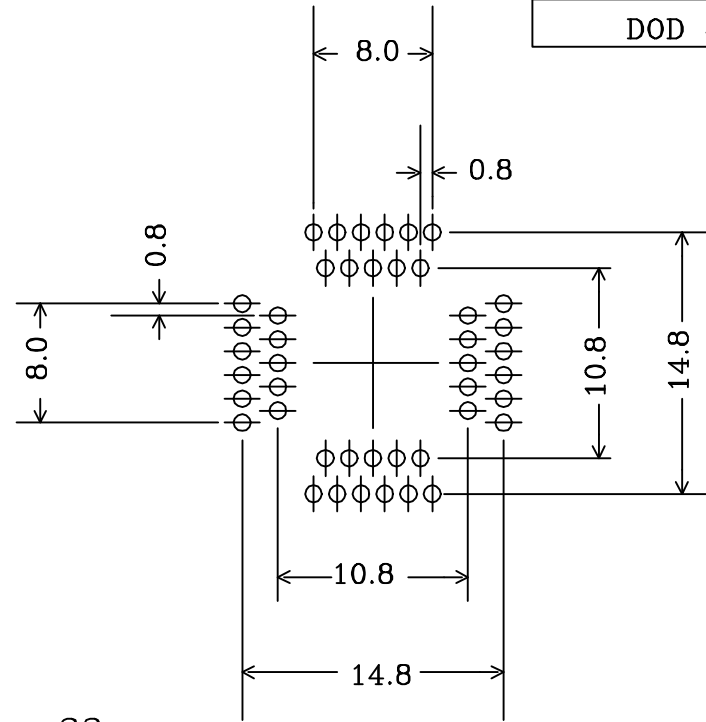
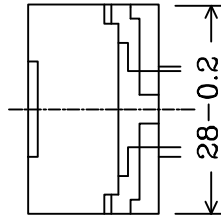
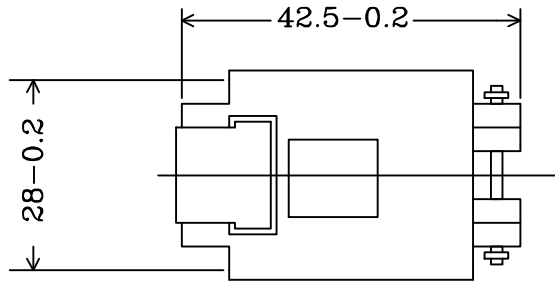
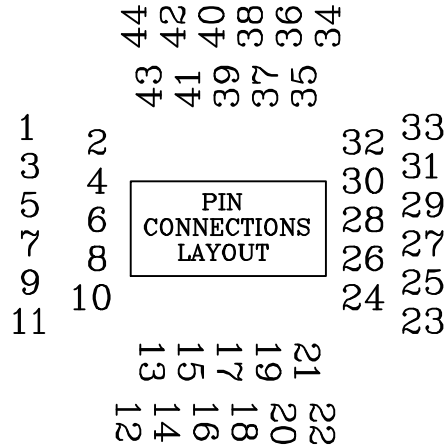

ET-PACKAGE CODE= 44-QF16A/B

- LEAD COUNT= 44
- BODY SIZE= 10.0mm
- LEAD PITCH= 0.8mm
- TIP TO TIP= 13.9/13.2mm

	Emulation Technology, Inc. — VLSI and SMT ADAPTERS and ACCESSORIES —	
	2344 Walsh Avenue, Bldg. F Santa Clara, Ca 95051	TEL:(408)982-0660 FAX:(408)982-0664
SHEET: 1 OF 1	DATE: 6-07-00	REVISION:
CHECKED: Paula Olson		DRAWN: Miguel Delgadillo
DO NOT SCALE DRAWING		TEST & BURN IN SOCKET E.T. PART #: S-QFP-00-044-A ID CODE: S-QFP-00-044-A