

SCALE 2:1

F6061

DOD 36061

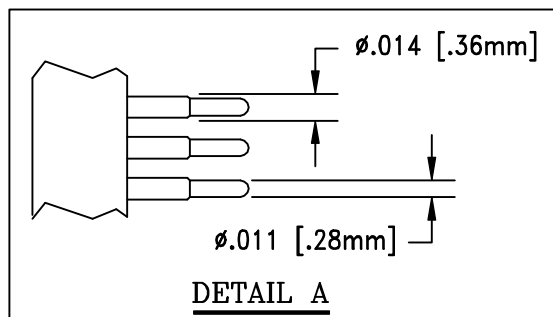
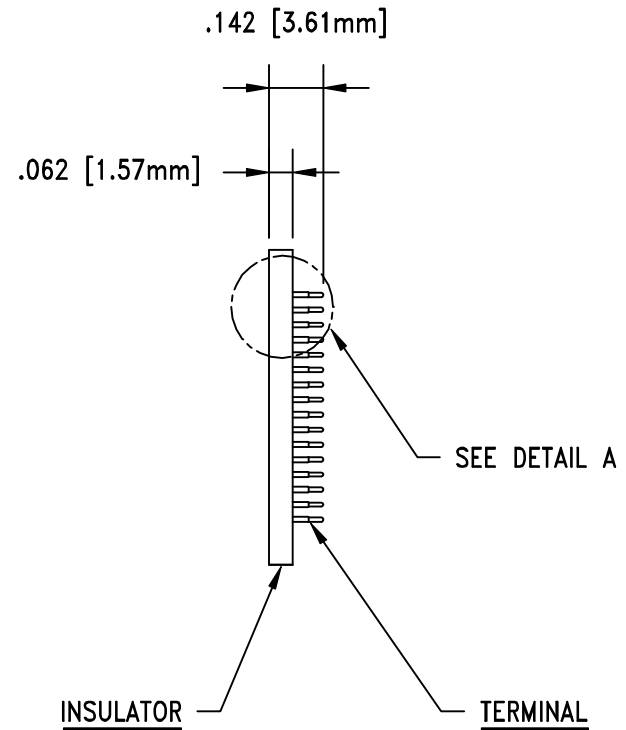
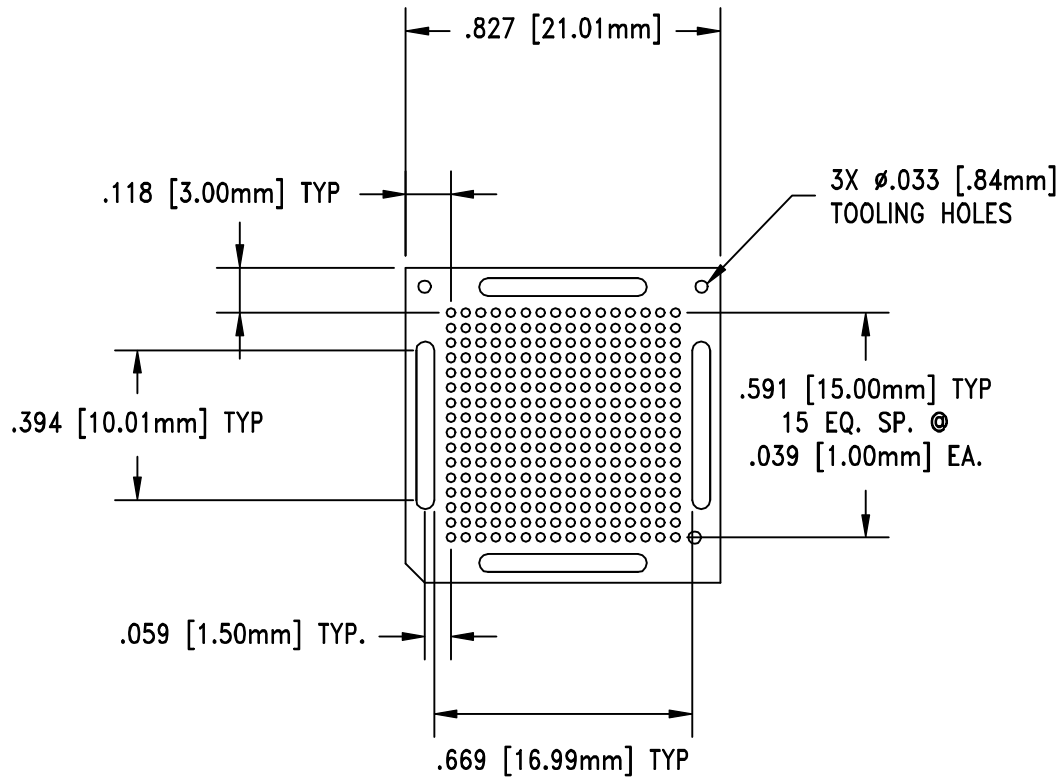

NOTES:

1. MATERIALS:

INSULATOR: FR-4 BLACK GLASS EPOXY U.L. RATED 94V-0 (UNCLAD)

TERMINAL: BRASS, C36000, ASTM-B-16

2. PLATING:

TERMINAL: 0.000010[0.000254] MIN. GOLD OVER 0.000050[0.00127] MIN. NICKEL.

ALL DIMENSIONS ARE IN INCHES UNLESS OTHERWISE SPECIFIED



**Emulation Technology, Inc.**  
 — VLSI and SMT ADAPTERS and ACCESSORIES —

2344 Walsh Avenue, Bldg. F  
 Santa Clara, Ca 95051

TEL:(408)982-0660  
 FAX:(408)982-0664

SHEET:  
1 OF 1

DATE:  
8-16-00

REVISION:

**ASSEMBLY DRAWING**

CHECKED:  
Paula Olson

DRAWN:  
Miguel Delgadillo

ITEM: FPA-256-3-016

DO NOT SCALE DRAWING

DESCRIPTION:  
FPA-256-3BG016-NS