

F3576

DOD3576

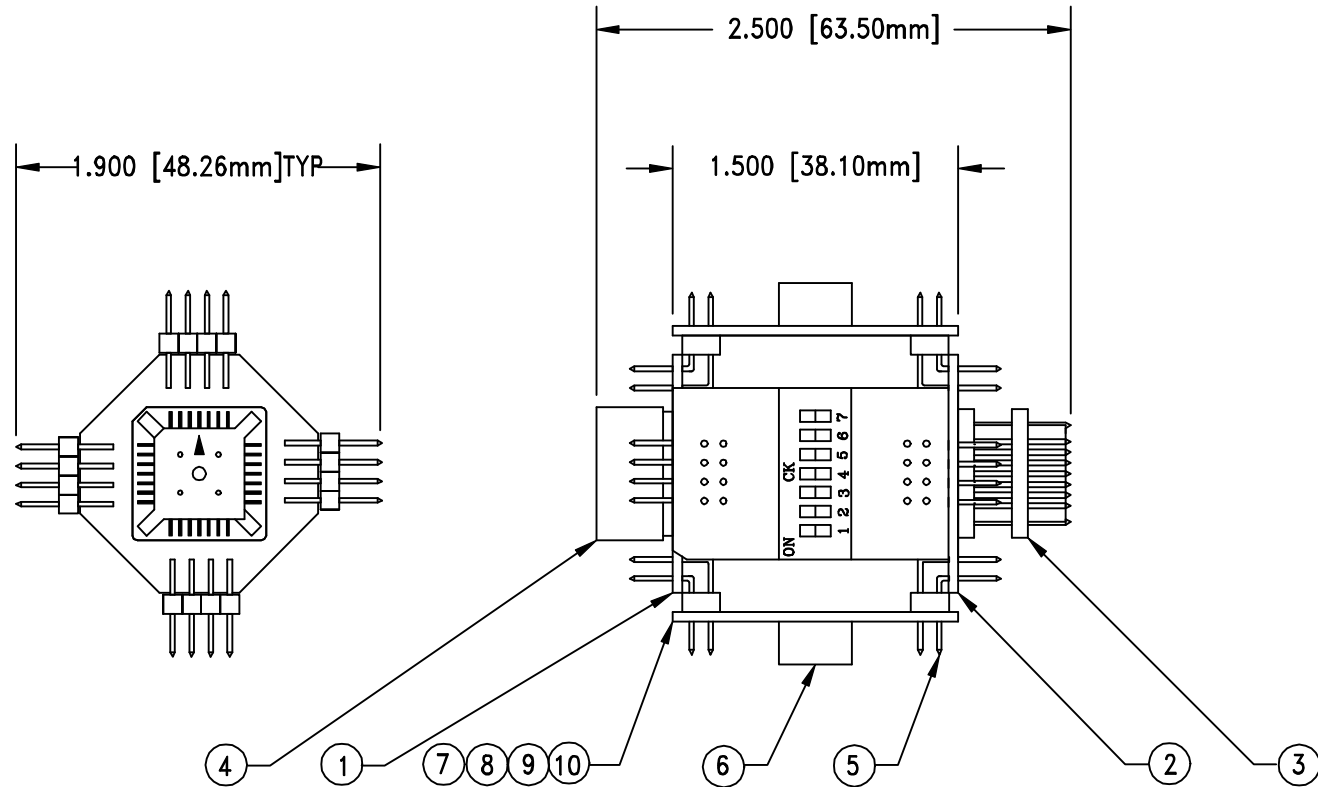

NO.	ITEM	DESCRIPTION	QTY.
1	BC4-28-PLCC	EMULATOR BOARD	1
2	BC4-28-PGA	TOP BOARD	1
3	BC4-28-SPACER-G	SPACER	1
4	S-PCC-06-028-A	TOP SOCKET	1
5	HEADER	RIGHT ANGLE PINS	1
6	SWITCH-7	MOUNT #10-#13	4
7	IS-28-01	SET OF 4 BARE BOARDS	1
8	IS-28-02	SET OF 4 BARE BOARDS	1
9	IS-28-03	SET OF 4 BASE BOARDS	1
10	IS-28-04	SET OF 4 BASE BOARDS	1

ALL DIMENSIONS ARE IN INCHES UNLESS OTHERWISE SPECIFIED



Emulation Technology, Inc.
 — VLSI and SMT ADAPTERS and ACCESSORIES —

2344 Walsh Avenue, Bldg. F
 Santa Clara, Ca 95051

TEL:(408)982-0660
 FAX:(408)982-0664

SHEET: 1 OF 1	DATE: 8/9/99	REVISION:
CHECKED: PAULA OLSON	DRAWN: JAMES GOUVEIA	
DO NOT SCALE DRAWING		

ASSEMBLY DRAWING	
ITEM:	04-00628
DESCRIPTION:	BI-028-PCC6-0