

REV	DESCRIPTION	DATE	BY
A	NEW DRAWING	08/23/05	H.N.

SKT2403

RETENTION FRAME

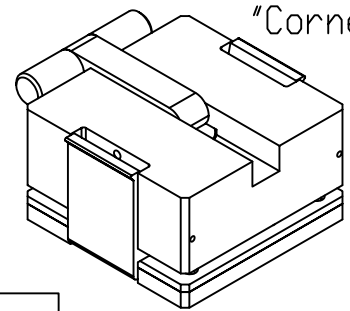
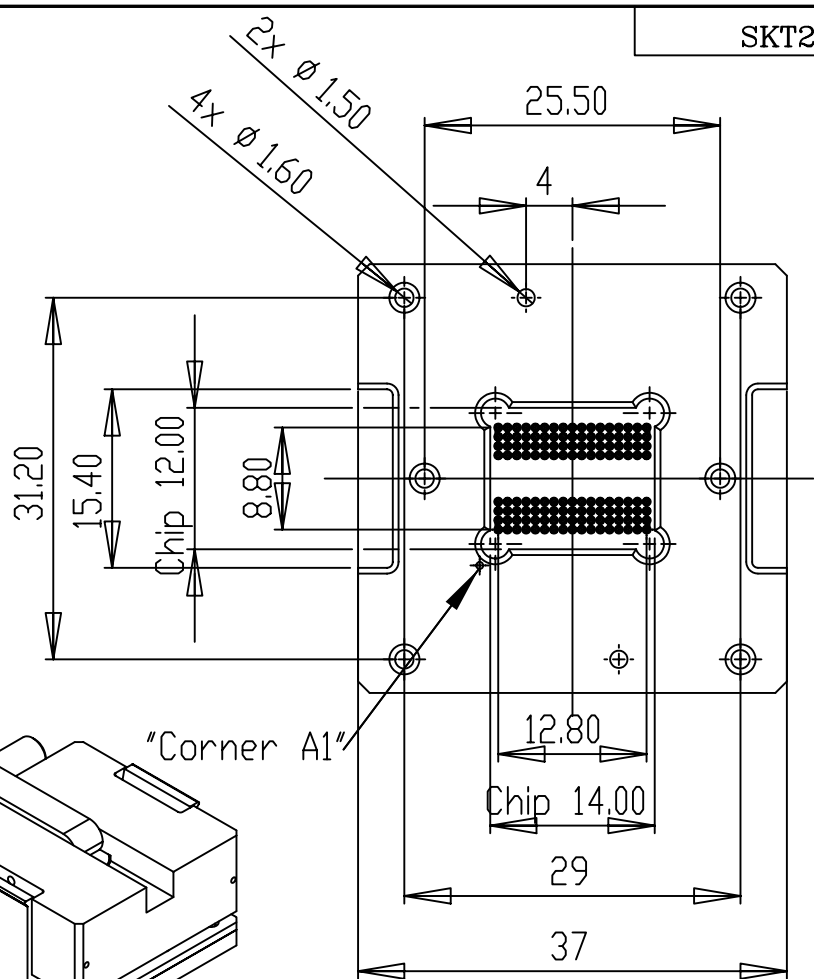
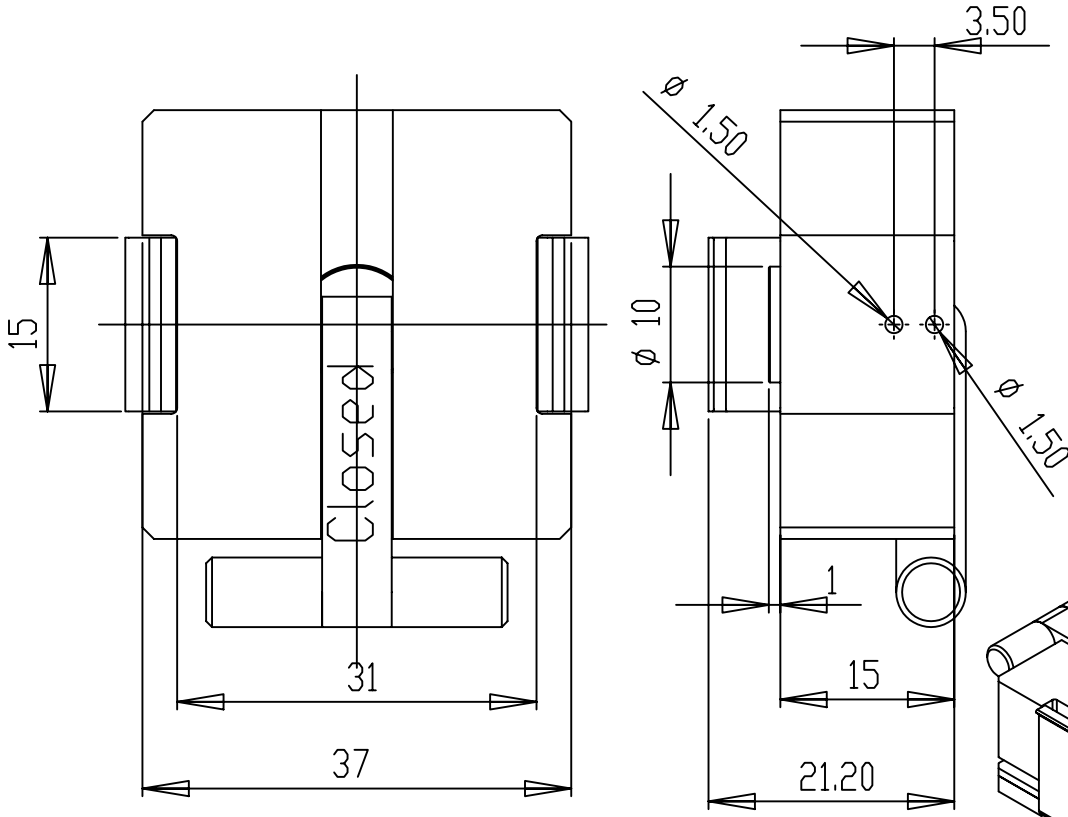

SOCKET

RECOMMENDED PAD LAYOUT

SOLDERTAIL STYLE		
REGULAR SMT STYLE	RAISED SMT STYLE	SPECIAL RAISED SMT STYLE
XX = (-SM)	XX = (-SR)	XX = (-SC)
YY = (-30)	YY = (-29)	YY = (-28)

SOLDERTAIL = THRU HOLE STYLE	
XX = (-ET)	YY = (-70)

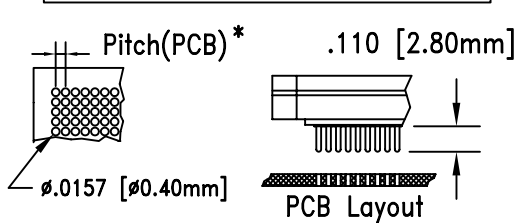
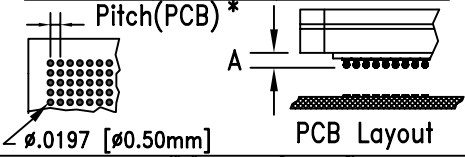

BALL DIAMETER FOR:	
-30(SM) = .0157 [0.40mm]	TO .0217 [0.55mm]
-29(SR) = .0157 [0.40mm]	TO .0217 [0.55mm]
-28(SC) = .0157 [0.40mm]	TO .0217 [0.55mm]

PIN DIAMETER FOR:	
-70(ET) = .0114	[0.29mm]

BALL HEIGHT FOR:	
-30(SM) = .0098 [0.25mm]	TO .0177 [0.45mm]
-29(SR) = .0098 [0.25mm]	TO .0177 [0.45mm]
-28(SC) = .0098 [0.25mm]	TO .0177 [0.45mm]

PACKAGE SPECIFICATIONS

PIN COUNT	= 136
LEAD PITCH	= 0.80mm
GRID SIZE	= 12X17
PACKAGE SIZE	= 12.00X14.00mm

ALL DIMENSIONS ARE IN MILLIMETERS UNLESS OTHERWISE SPECIFIED

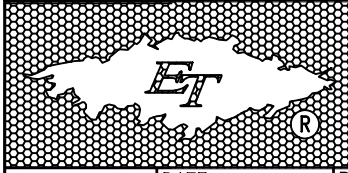

Emulation Technology, Inc.
— VLSI and SMT ADAPTERS and ACCESSORIES —

2344 Walsh Avenue, Bldg.F
Santa Clara, Ca 95051
TEL:(408)982-0660
FAX:(408)982-0664

SHEET: 1 OF 1	DATE: 08/23/05	REVISION: A	ASSEMBLY DRAWING
---------------	----------------	-------------	-------------------------

CHECKED: Perry Munroe	DRAWN: Huy Nguyen	ITEM: S-MBQ-17-136-XX
-----------------------	-------------------	-----------------------

Scale N/A	DO NOT SCALE DRAWING	DESCRIPTION: BPQ-136-6BG12X17-YY
-----------	----------------------	----------------------------------

* All Dimmensions Are Nominal For A .0315 [0.80mm] Pitch BGA Package